

---

HALAL-CHAIN WHITE PAPER

---

Halal Chain Team

Version-: 2017/11



*“We have the infrastructure, the strategic location at the heart of the Islamic world, in addition to the long experience in Islamic economy, Islamic banking, Sukuk and Islamic insurance; and we have, above all, the determination and ambition to achieve our goals.”*

*H.H. Sheikh Mohammad bin Rashid Al Maktoum  
Vice President and Prime Minister of the UAE and Ruler of Dubai*



*“I am optimistic about achieving the goal of Dubai in becoming the world’s Capital of Islamic Economy. Dubai has sufficient experience, the ultramodern infrastructure, as well as the appropriate strategic geographical location in the heart of the Islamic world. But most importantly, we have H.H. Sheikh Mohammed bin Rashid Al Maktoum who leads Dubai with all the wisdom, confidence and resolve towards the future.*

*The emirate is building on that achievement by constantly working to foresee the future and keep up with the fourth industrial revolution and all the prospects of increased efficiency that come along with it.”*

*H.H. Hamdan bin Mohammed bin Rashid Al Maktoum  
Crown Prince of Dubai and Chairman of the Dubai Executive Council*

# 1. What is Halal?

## 1.1. Halal Food Overview

The term “Halal” is an Arabic word, which means lawful, legitimate, allowed or permissible.<sup>1</sup> From the Islamic legal perspective, halal is something which is allowed and permitted by the sharia (the Islamic law). It is the opposite of “haram” which means prohibited under the Islamic law.<sup>2</sup> A basic understanding of what is halal and abiding by the sharia rules of halal is central to every Muslim’s belief. An Islamic legal maxim is stated as:

*“The fundamental ruling in matters is permissibility, unless an evidence proves the prohibition.”<sup>3</sup>*

The concept of halal is quite influential in all aspects of a believers’ life, because it provides a comprehensive set of rules and guiding principles. That is why, halal defines a consumer product or a group of consumer products where the sharia principles and measures should be observed throughout various stages of the supply chain process, including production, transportation, and distribution phases.

According to the Islamic teachings, a person’s spirituality and his/her purity of soul are strongly related to consumable goods, particularly the edible goods. With this understanding, consumers are demanding for an increased production of halal food. It is this gap that the commercial halal food sector seeks to fill. With the Holy Quran calling for the food to be halal and pure,<sup>4</sup> or Tayyib; Allah has mentioned in Surat al Mu’minun that:

“O messengers, eat of the good things (Tayyibaat), and act with integrity. I am aware of what you do” (23:51)

This has led to segments of the Halal Food sector creating produce of the highest quality, as can be seen in the rise of Halal organic food. Consequently, non-Muslim demand for such quality food is also increasing.

---

<sup>1</sup> Baalbaki, R. (1995). Al-Mawrid. Beirut, Lebanon: Dar El-Ilm Lilmalayin.

<sup>2</sup> Mausoo`ah Al-Fiqhiyyah Al-Kuwaitiyyah. (2007). Under the term ‘Halal’.

<sup>3</sup> Al-Sayuti, A. R. (1990). Al-Ashbah Wa Al-Nadhair. Beirut, Lebanon: Dar Al-Kotob Al-Ilmiyyah.

<sup>4</sup> The Holy Quran, Al-Baqarah, 2:168 “People, eat what is good and lawful from the earth, and do not follow Satan’s footsteps, for he is your sworn enemy.”

## 2. Status of the Global Halal Economy

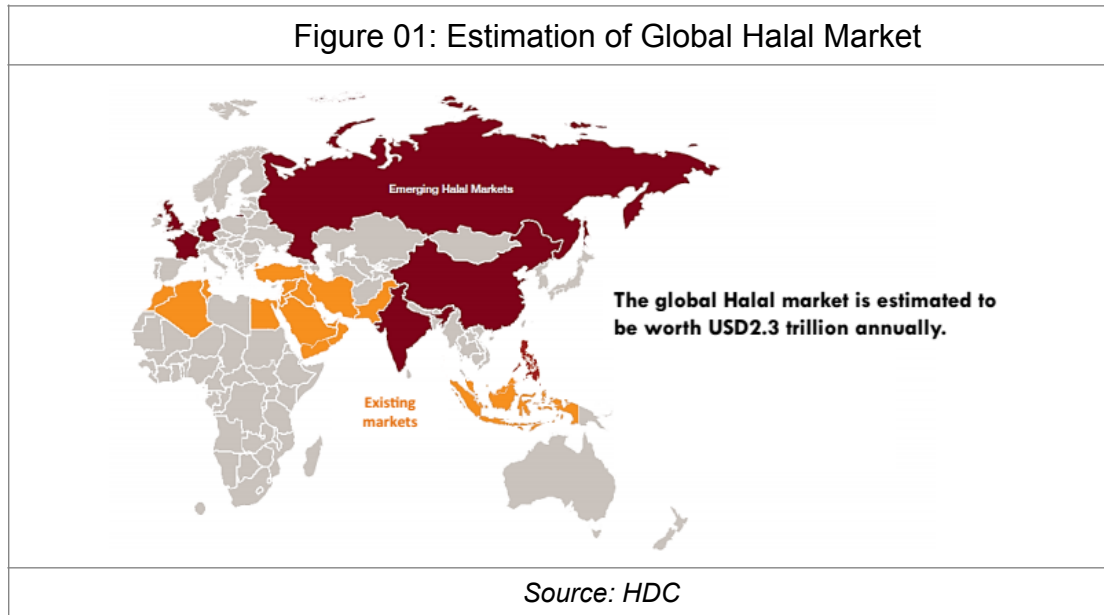

According to the State of the Global Islamic Economy Report 2016-7 by Thomson Reuters, the global halal economy is estimated to be worth around USD 3.9 trillion. Growing at an estimated annual rate of 20%, the industry is valued at about USD 560 billion a year. Thus, making it one of the fastest growing consumer segments in the world. In 2018, it is expected to hit the USD 6.4 trillion mark.<sup>5</sup>

The global halal economy consisting of 1.8 billion Muslims is no longer confined to food and food related products. The halal industry has now expanded to include pharmaceuticals and health products, cosmetics, media and recreation, fashion, traveling and medical devices as well as service sector such as logistics, marketing, print and electronic media, packaging, branding, and financing. In recent years, with the increase in number of affluent Muslim consumers, the halal industry has expanded further into lifestyle offerings including halal travel and hospitality services as well as fashion. This development has been triggered by the change of the mindset of Muslim consumers as well as ethical consumerism worldwide.

<sup>5</sup> WIFE. (2016). Global Halal Economy Estimated to Touch \$6.4 Trillion Mark by 2018. The Gulf Today, 15th November 2016.

## 2.1. Potential Market Opportunity for the Halal Ecosystem – The Global Muslim Population



The global Muslim population is expected to grow by about 35% over the next 20 years, rising from 1.6 billion in 2010 to 2.2 billion by 2030. By 2050, the Muslim population could grow to 2.6 billion representing nearly 30% of the projected global population.

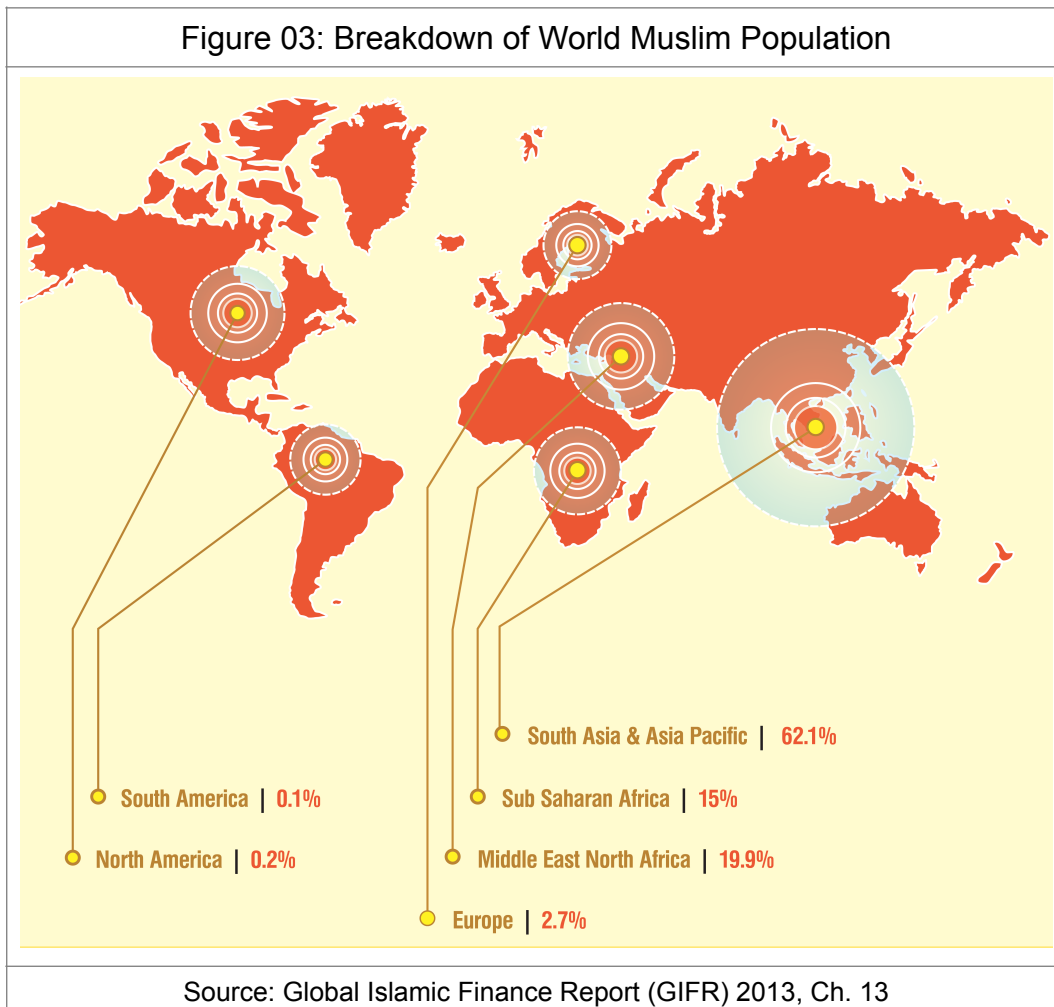

By 2030, Muslim population is expected to spread to 79 countries, rising from the current figure of 72 countries. The majority of the world’s Muslims (more than 60%) continue to live in the Asia Pacific region, while almost

20% live in the Middle East and North Africa. Elsewhere, the Muslim population in Europe and the Americas is expected to grow at a slower rate, but still constitutes a rising share of the total population in their regions.

A major factor that makes the Muslim market particularly attractive to a variety of companies is its largely young demographic profile that is part of an emerging middle class linked to greater consumption. Notably, Islamic doctrine is also supportive of both trade and consumption activities. In Islamic majority and minority countries throughout Asia, the Middle East, Africa, and Europe, Islamic business activities are escalating, with Islamic trade currently estimated in trillions of dollars. The Islamic market is huge, lucrative and underserved; thus, provides opportunities for halal products and services.

Recently, the advent of modern technology at the global level brings up unprecedented business opportunities and also numerous challenges for global halal industry. The industry has been fully accelerated by breaking through traditional business models expecting a vast market potential to be materialized.

## 2.2. The Current Challenges in the Global Halal Industry

### ■ ***Lack of Globally Reorganized Halal Certification System***

The absence of standardized halal certification system at the global level has given rise to technical barriers for cross-border trading of halal products among international economies.

### ■ ***Inaccurate and Unauthentic Data of Halal Products***

Halal products that are not authentically certified or lacking transparent mechanism of certification can cause trust issues and delays in setting up a global distribution system. Moreover, the dearth of data of halal products simply adds up to the concerns. Sometimes, the data is available, however, it is found to be either inaccurate or unauthentic.

### ■ ***Poor Regulation of Raw Materials for Halal Products***

There is no heavily regulated market for raw materials of halal products. Such unavailability enables non-sharia-compliant ingredients and materials to be mixed with the halal food. In this situation, it is difficult to avoid this contamination due to the complexity and inter-connectivity of the world food supply chain. As a result, it is increasingly difficult for any halal certification agency to perform its duty of ensuring sharia-compliance of food.

In these circumstances, such weakness damages Muslim consumers' confidence in many ways. Due to the current industry landscape, the establishment of a uniformed regulatory framework is not possible within a short time span.

- ***Centralized Regulation for Halal Food***

A centralized regulatory system for halal food is sufficiently difficult to manage and regulate the industry across the whole chain due to challenges and issues in its implementation. The methods, technology and regulatory bodies across the globe that run halal food supply chains have not kept pace with growing concerns of our modern Muslim world.

In response to the challenges listed above, the Halal Chain provides the solution which is required for the efficient expansion of the Halal Industry.

## 3. What is Halal-Chain?

*Halal-Chain is a decentralized global monitoring solution for product safety and integrity which is achieved by harnessing the power of the technology of consortium chain, with the particular attention in the field of Halal industry, including food, medicine and cosmetics.*

### 3.1. Consortium Chain for Halal Products Traceability

- **Technical Selection of Halal-Chain: Public Chain Vs Decentralized Consortium Chain**

In recent years, blockchain technology has attracted exponentially growing attention of the masses. This trend is an ode to the decentralized general computing capability by the public blockchain, and the introduction and application of the consortium chain technology by the professionals in the circle of traditional mainstream technology.

The actual uses of the Halal-Chain comprise of a far more complex ecosystem, taking every factor into consideration; such as regional laws and cultural diversities, industry implementations, and extensibility, security and stability of the system. In order to establish a cross-regional Halal-Chain, the criteria such as stated below must be checked:

- Regional differences in laws, regulations, and culture;
- Special requirements of halal industry and business scenarios;
- Optimized governance mechanism of the multi-center and multi-node collaboration;
- Performance requirements for throughput, latency and others;
- Special requirement for data storage; and
- Accessibility.

After a comprehensive review and technical due diligence of the public blockchain and consortium blockchain, the Halal-chain adopts Qtum as the foundational blockchain technology and incorporates Hyperledger Fabric technology, which could materialize cross-chain data exchange between public blockchains and consortium blockchains as proposed by the Ink Chain team.



Based on the above mentioned technical feasibility study and the strategic partnership with Ink Chain and Qtum Chain, the Halal-Chain's technical solution is oriented to cater for the traceability of halal products that should be operated within a trustworthy consortium blockchain confined in a limit circle. This enables the system to address the concerns of cross-chain data exchange and data storage. At the same time, the Halal-Chain achieves its primary objective for the halal industry. In brief, a consortium blockchain that is developed for a specific industry has inherent advantages in addressing the concerns and issues in the traceability of halal products.

In this way, the traceability system for halal products in the Halal-Chain solution contributes to the entire Halal-Chain ecosystem. In addition, the ecosystem also consists of tokens issued on Qtum blockchain considering the most relevant economic model. At the same time, it has the element of the cross-chain protocol between ink chain and Halal-Chain.

▪ ***Technical Implementation of Halal-Chain for the Traceability of Products***

The consortium blockchain of the Halal Chain is a tailor-made blockchain space developed for the Halal products traceability. Its underlying framework comprises of multi-specifications and standards of Qtum, Halal-Chain, and Hyperledger Fabric. It has been optimized and upgraded based on the actual business cases of the industry.

▪ ***Identity and Access Management***

The Halal-Chain adopts a digital certification mechanism for identity authentication and access control. Through certified authority, a trusted third party – trusted by both the subject (owner) of the certificate and the party relying upon the certificate – ascertains that the public key of the subject and other identification information are bound together to verify a user's identity.

The identification authentication process used in the consortium blockchain is as follows:

- The subject submits its basic information (name, serial number, contact details, etc.), affiliated node information (internet protocol (IP) address, node identity), and certification authority (CA) public key certificate for the operator for a uniformed access control
- Once access is approved by the operator, the relevant information of the subject is publicly announced at the consortium blockchain, which

connects the node of the subject to the network by enabling node handshake and establishing connection.

- Once nodes are connected, the nodes use the private key in the CA certificate to sign their own handshake information and send it to other party. The receiver will then query the CA public key certificate according to the handshake information of the sender and verify the signature through the public key certificate, so as to identify which subject has initiated the connection, and whether or not it should allow to set up a communication.
- The certificate management committee checks the status of the subject's certificate on a regular basis to find out whether the certificate is still valid, expired or revoked. If the subject's node tries to connect to the network, while the certificate is found to be invalid, it will be rejected by the system.

#### ■ ***Node Management***

A node is a deployed server on the Halal-Chain platform. It can be connected to the consortium blockchain network with an accessible IP address and is able to provide services to external parties.

The nodes are categorized as central node and enterprise nodes in order to prevent attacks from malicious nodes. Only the nodes certified by the consortium blockchain can act as the central node. It is entitled to participate in the consensus algorithm and to act as the ledger in the chain. On the other hand, enterprise nodes upload data, while also serving as the ledger in the chain, but they are precluded from participating in the consensus algorithm.

#### ■ ***Consensus Mechanism***

The Halal-Chain uses the PoL & T (Proof of Land & Time) algorithm. It uploads data based on time and land. Due to differences from the land and time in generating data, it limits the possibility of counterfeiting the data. The traceability of data about halal products would be produced based on time and land through marketing incentives.

#### ■ ***The Decentralized Halal Products Traceability Platform***

The decentralized platform for the traceability of halal products is established as niche market based on Halal-Chain ecosystem. A variety of technical solutions would be offered to enterprises, regulators, end-consumers, developers and other industry stakeholders, enabling the users to trace halal products across the whole supply chain.

## 3.2. Fundamental Reasons for Change

Subject to the structure of blockchain, smart contracts and their unique ecosystem, the technology enables decentralized applications (Dapps) to offer products' data for public review and avoid its artificial tampering which may occur during the course of production and transportation due to other complexities of the supply chain.

- ***The Changes***

- Redefining Roles

The decentralized model distinguishes the role of manufacturers and the traceability of products provided. Thus, this would enable the product traceability information to be offered credibly and authentically.

- Redefining the behavior

All the data will be collected and uploaded in the production process by Internet of Things (IoT) devices automatically without any involvement of the enterprises. The blockchain platform would be self-governing to ensure the uniqueness and accuracy of the product traceability data.

- ***Capabilities and Services***

- Products' Traceability Services

The measurement will be automatically collected and updated by IoT devices, in conjunction with blockchain technology which is tamper-resistant, and features time stamp. The services will be offered to the enterprises and end-users for the purpose of product safety and maintaining integrity to enhance the core competitiveness of the applied enterprises.

- Auditing Services for Regulating Bodies

The service will offer an auditing interface for the regulators by providing access to production data to safeguard all the products manufactured in compliance with relevant regulations and laws in various jurisdictions.

- Anti-Counterfeiting and Verifying Services

All the data in the blockchain would be open for public review. The end users could use the relevant mobile/web application to verify and trace the product throughout its entire supply chain.

- ***Vision of the industry changes***

Subject to technical feasibilities, it is intended to help industries realizing the vision for a traceability system in the long run, where:

At a decentralized platform, the production information is automatically collected and uploaded by the IoT devices to the blockchain platform. It is significantly crucial because manual input process may be contaminated by human errors, mistakes or data deviation due to a variety of objectives and subjective factors.

The end user's loyalty, confidence and trust in products will be significantly enhanced, since all the data in the blockchain would be open for public review and the production process will be vividly displayed to demonstrate decency and authenticity. Therefore, the brand build-up for industry stakeholders will likely be elevated.

From the perspective of regulators, at the event of any incident in the production, it might be unnecessary to deploy a host of manpower and time to conduct ordinary investigation, because the essential production information could be easily traced via the blockchain platform.

- ***Blockchain from Islamic Economics perspective***

The main efforts in Islamic economics so far has been to create new forms Shariah compliance instrument to operationalise Shariah values and ethics into the current conventional economic system and banking products.

While this is crucial to sustain the global economy as it is today, the Islamic economics needs to develop new strategies to cope with the next economy, which starts with a clear and deliverable vision of a new world economy. And the new vision of a new world economy will be driven by those who embrace innovation that will build the future.

However, it is necessary look at the main building block to enable trust in impersonal financial transactions in a highly globalized society. This innovation called the "blockchain" will play a crucial role in boosting the Islamic financial sectors in all its segments which include banking, insurance, Capital market, etc. Addressing the digital revolution that is happening right now will foster competitive advantage for the Islamic economy industry. This innovation is in accordance with Shariah rules and principles

The blockchain lets people who have no particular confidence in each other collaborate without having to go through a neutral central authority. Simply put, it is a mechanism for creating trust. Within this open ledger system, the blockchain offers an inherent level of trust for the user, eliminating the need for the middleman and mitigating the risk of human error. Justice and creditworthiness has been emphasized in the Holy Quran in Surat al Nisa which Allah says:

O you who believe! Stand firmly for justice, as witnesses to Allah, even if against yourselves, or your parents, or your relatives. Whether one is rich or poor, Allah takes care of both. So do not follow your desires, lest you swerve. If you deviate, or turn away—then God is Aware of what you do” (4:135)

In the blockchain transaction, it is publicly accessible log of transactions ensures that the data is protected against tampering and revision, and it is virtually impossible for individuals to modify or replace parts of the blockchain secretly.

The need for transparency is, above all, an important Sharī`ah consideration in blockchain transaction. Any form of concealment, fraud or attempt at misrepresentation violates the principles of justice and fairness in Sharī`ah as mentioned in the Qur’an in Sūrah Al-Mutaffifin:

Woe to the defrauders. Those who, when they take a measure from people, they take in full. But when they measure or weigh to others, they cheat. (83: 1-3)

A full copy of the blockchain contains every transaction ever executed, making information on the value belonging to every active address (account) accessible at any point in history. Every block contains a long reference number or hash of the previous block, thus creating a chain of blocks from the genesis block to the current block. The below paragraphs explain the concept of blockchain and how a transaction is recorded on the blockchain, based on the cryptocurrency protocol.

## 4. How Does the Halal-Chain Solve the Problem?

*The Halal-Chain is a Halal products traceability platform on Qtum, inclusive of its corresponding tokens and ecosystem.*

### 4.1. HALAL Product Traceability Platform

The Halal-Chain is defined not only as the product traceability platform, but also as a complete ecosystem, which is illustrated below:

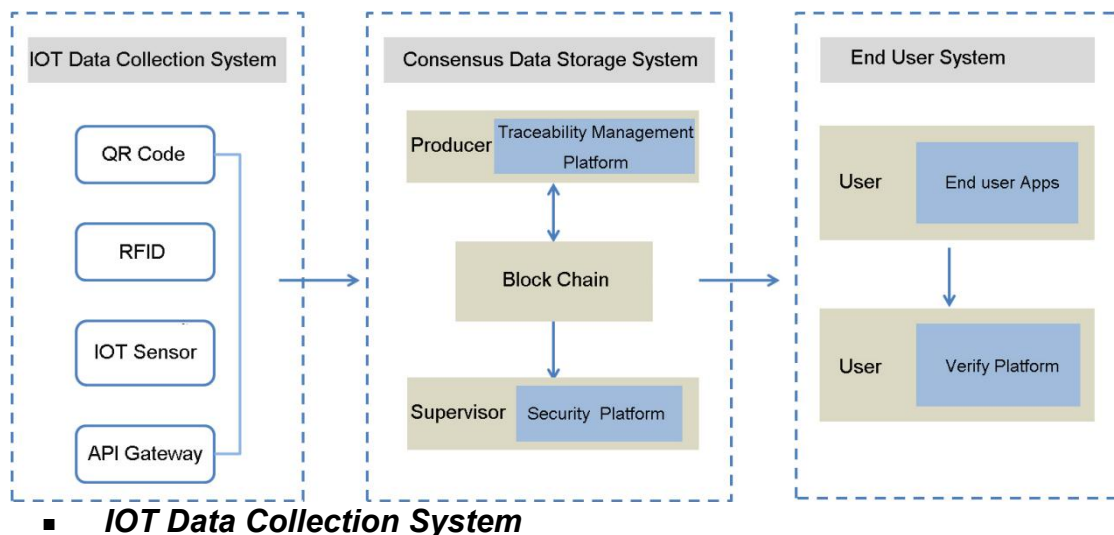

#### ■ ***IOT Data Collection System***

The core value of the IoT system is that the production information would be automatically collected and uploaded by the IoT devices to the blockchain platform without any manual involvement. Thus it safeguards the uniqueness and credibility of the data.

#### ■ ***Consensus Data Processing and Storage System***

The blockchain platform based on Qtum and Halal-Chain can realize classified storage of the data collected by the IoT devices. The consensus data would be stored in the blockchain, while the image data and product data would be stored in the InterPlanetary File System (IPFS) distributed storage system via the adoption of Merkle tree technology from Ethereum.

- **End-User System**

As for the part linked with end-users, the halal products traceability platform can provide tracing and verifying services. It can also serve as a token exchange service.

- **Branch Platform of IoT data Collection System**

- Tags, Radio-Frequency Identification (RFID), Near-Field Communication (NFC) Data Collection System and Sensor Systems

A key attribute of the Halal-Chain is its comprehensive support to all RFID and NFC-based data acquisition devices in the industry. This feature provides the ability to tag and monitor physical objects and transmit data associated with them. It allows goods to be tracked throughout the supply chain and assures full integrity of readings. The Halal-Chain primarily collects data from tags, tracers, sensors, and other IoT devices.

A tag is an element set on the product itself, generally on top of the packaging, that provides information about the product and its identity. 1D/2D barcodes, RFID stickers and NFC are examples of common tagging systems, which would be used to trace the product flow information. The significant part of the Halal-Chain is that the tags integrate all essential information in the production, which includes consensus data, pictures, product data, etc.

- **Data Detection System**

In order to implement relevant regulations and specifications required by regulatory bodies, specific detection systems are selected and deployed by Halal-Chain at various stages to offer the most effective and cost-efficient assessment of each product at every stage. A product's physio-chemical structure, composition and quality attributes may vary throughout the supply chain and must be continuously assessed to verify conformity with standards set by participants in the network, which will prevent counterfeiting of products.

The data detection device, an IoT hardware, deployed in the supply chain, provides an automatic data acquisition and input system that results in a credible and authorized input process.

- **Data Transmission**

When information is transmitted from a device to the Halal-Chain network, it includes:

- Tag IDs, location and time, tracer, sensors and gateway IDs;
- Digitized certificates and transaction IDs;
- Transportation, handling and storage conditions as measured by sensors; and
- Product quality and safety attributes

## 4.2. Working Mechanism of Halal Products Traceability Platform

The diagram above shows how data is transmitted across the Halal-Chain.

- Data acquisition in production process
- Data collected by an IoT device is uploaded to the Halal-chain platform through the API edge gateway
- The block chain platform verifies the data source transmitted by the edge gateway to ensure that the data is uploaded via a certified node
- The Blockchain platform conducts classified storage of the authenticated data, and alerts all nodes in the consortium blockchain.
- The end-users use APP to verify product authenticity
- The regulators conduct auditing to all products in the Halal-Chain platform
- ***Halal-Chain Protocol***

The system architecture of Halal-Chain consists of a variety of underlying blockchains and IoT technologies in which each specific technology is an integral part of the entire ecosystem. The major elements of the architecture are as follows:

- ***IoT Data Acquisition Device***



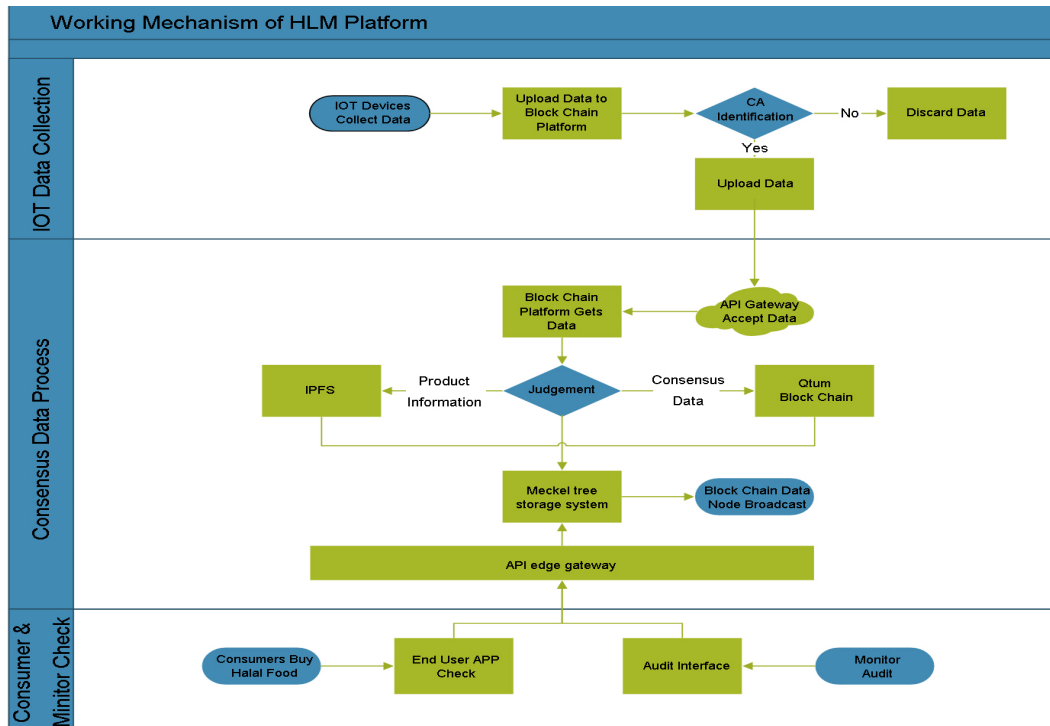

The function of the device is to collect product information in the supply chain, such as time, place, pictures, products and so on.

### ■ **Data Acquisition**

The platform is designed to manage a distributed data set based on Qtum blockchain and IPFS. The smart contract records every essential information and relevant features of the product in the supply chain. The smart contract is featured with the following characteristics:

- **Authenticity:**

The Halal-Chain authenticates devices by using public-private key cryptography. Each device on the network signs data transmissions with its unique private key to prove its identity as an authorized device. Signatures from devices are verified against a list of authorized devices, which is a mapping of public keys to devices that is publicly available in a smart contract.

When an authorized device sends a message to the Halal-Chain network, its public key is compared to the Authentication list for verification. Once verified, the message is accepted and recorded onto the blockchain. If an unauthorized device sends a measurement, the signature verification will fail and the measurement will be rejected. This would ensure the accuracy of the data on the blockchain.

The diagram below demonstrates a data transmission from a measurement device to a customer device that is authorized on the Halal-Chain.

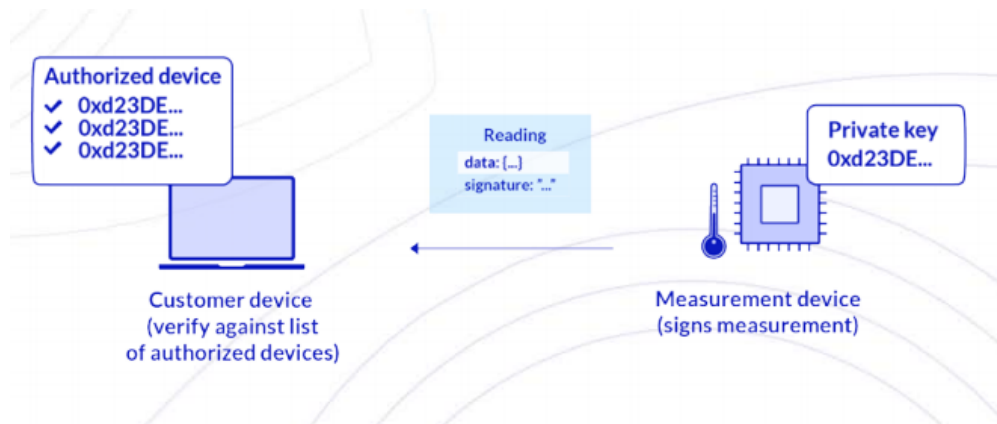

- Disclosure and Transparency

The data on the blockchain uploaded by the IoT device is publicly available.

- Tamper-proof

The data on the blockchain uploaded by the IoT device cannot be modified or deleted by any party.

- Block Space Capability

The block space capability reflects its storage capacity for data packet. Although a single measurement is typically small, the system is designed to collect thousands of measurements per batch which may include data from multiple devices, such as pictures, videos, product information and so on. Thus, in the long term, the Halal-Chain network will need to handle terabytes of data daily, which might lead to transaction jam.

To achieve this network capacity, Halal-Chain has created a blockchain that integrates with the Ethereum blockchain and an IPFS distributed storage system, enabling the consensus encrypted data to be stored in the blockchain while the IoT measurement data would be stored in the IPFS. The measurement data is stored as leaves in a Merkle tree. The measurements tree nodes are then mapped to IPFS nodes. A Merkle tree is a structure that allows any party to quickly verify the validity of data in a branch or leaf using the root hash of the tree.

Storing the Merkle tree root on the blockchain ensures the data cannot be modified once it is written in a block. Halal-Chain also maintains the entire history of all Merkle roots to ensure that no data is lost or altered during Merkle tree updates.

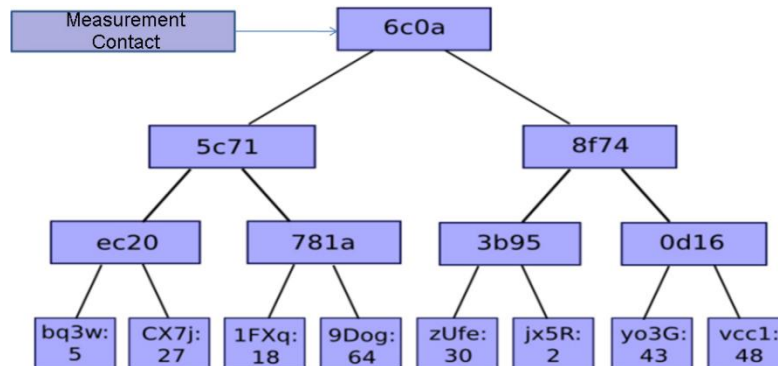

### ■ **Smart Contract Enforcement**

Similar to ISO9001 quality certification, the products will not be allowed to trade or circulate unless its production quality fulfills the enforcing standards. The Halal-Chain platform will open access to the relevant authorities for auditing and supervision.

## 5. Halal-Chain Coins

The economic model of Halal-Chain is based on the cross-chain protocol and consortium blockchain. In the ecosystem, the token Halal-Chain Coin (HLC) will be issued on Qtum to act as the utility token.

### 5.1. Other Business Considerations

- ***HLLC Bonded Halal Products***

The tokens, HLC, are bonded to data. As items move through the supply chain and are transformed during the manufacturing process, a random token reward (*the initial reward amount is 1 token, and would reduce half according to the progress. The 2% of the total tokens is expected to be allocated for this marketing campaign*) assigned can be split and merged into multiple other Measurements Smart Contracts, which together create a graph representing the history of a given item. The HLC tokens are sent to the network alongside IoT data, and remain locked in the Measurements Smart Contract, until a batch completes its movement through the supply chain.

The HLC tokens remain bonded to a product until a defined expiration date or until the “termination event”. The termination event can be defined by a purchase, delivery, product destruction or any other event on the supply chain.

The end users can claim tokens at the end of the product cycle, which could be used to redeem credits or a bonus from the official website. In this way, the tokens can be recycled and returned to the ecosystem (the tokens will be destroyed by the smart contract if the product is destroyed or recalled). The value gained by recycling tokens motivates users to purchase Halal Chain-tracked products. This cycle also benefits producers who receive free promotion and brand building.

- ***Token Investment to Industry Stakeholders***

A certain number of tokens will be used to acquire the ownership of certain industry stakeholders, which is going to bond the token with real economy and nourish the global Halal ecosystem.

### 5.2. Cross-Chain Protocol

The Halal-Chain cross-chain protocol is fully developed by Halal-Chain team by harnessing the only sophisticated solution in the blockchain space that could materialize cross-chain interaction between public blockchain and consortium blockchain. Its details are given below:

*“For consortium blockchains distributed under various sovereignty frameworks, the capability of cross-chain interaction is key to realize the Internet of Value. The public blockchain (Qtum), sitting at the very heart of the Halal-Chain ecosystem, becomes a natural bridge in the transfer of value and information.*

*In the early days, side chain solutions such as the two-way peg have contributed to extending the scalability of bitcoin. Later, smart contract platforms such as Ethereum provided more possibilities to cross-chain interaction scenarios and protocols. Some delicate projects like BTC (Bitcoin) Relay enabled Ethereum DApp developers to verify the bitcoin network activities via smart contract. Other projects aimed to realize the “Internet of Blockchains”. For instance, Cosmos and Polkadot are seeking to realize cross-chain value transfer or a global consensus through hub or relay mechanism. Till date, most efforts made in cross-chain interoperability remain in the early stages or are restricted to the domain of public blockchain. The latter is due to the immature development of consortium blockchain as there is a lack of conducive environment for exploration and testing.*

*As Halal-Chain sovereign consortium blockchain prospectively extends Fabric to support multi-asset accounts and tokens, the problems mentioned above will be solved. We devote to realize the interoperability of Halal-Chain sovereign consortium blockchain with Qtum as it is a key process in prospering the Halal-Chain ecosystem. The interoperability shall realize the reliable asset transfer, cross chain orable and cross contract operation.*

*The realization of interoperability will benefit from the following two aspects. Firstly, as highly versatile and general smart contract platforms, both the Ethereum Virtual Machine(EVM) supported by Qtum and chain code which are supported by Halal-Chain consortium blockchain have flexible and powerful capability of expression. Secondly, the Halal-Chain consortium blockchain itself provides and also relies on the identity management and access control mechanisms. Therefore, cross-chain operations can rely on multiple trustworthy endorsers just as the transactions do, without extra premise on the trust of the consortium system.*

*On the side of the consortium blockchain, the whole consensus process is decoupled into transaction endorsement, ordering and validation, performed by different network nodes. Furthermore, we introduce cross-chain relay endorsements. The network nodes in charge of cross-chain relay need to independently query and verify the cross-chain operation event on Qtum as well as the corresponding state value (and ensure fair finality). They are also responsible to sign the legal cross-chain operation proposals of the consortium blockchain side. Just as the transaction endorsement policy set for instantiated chain code, relay endorsement policy is also needed for cross-chain operations. Specifically, Signature Policy structure can be applied to specify the valid relay endorsements, forming any complicated signature combination. For instance, “OR (‘Org1.member’), AND (‘Org2.member’, ‘Org3.member’)” indicates that the condition of the policy can be met with the signature of an Org1 member or with the signatures of both Org2 and Org3 members.*

*On the Qtum side, the consortium blockchain in need of cross-chain interoperability will be registered via smart contract. The basic information and current relay endorsement policy are recorded, and the triggering of the contract terms also need to satisfy the specified signature combination”*

### 5.3. Use cases

Through adoption of the technology, HLC are based on the Halal-Chain ecosystem on Qtum. A token-holder can transfer the tokens safely to a certain Halal-Chain sovereign consortium blockchain through cross-chain protocol. Those tokens on the consortium blockchain will be generated and managed by the ASCC correspondingly. They can be circulated freely by means of direct transfer or triggering smart contracts. Moreover, users can also transfer tokens back to Qtum securely, if necessary.

## 6. Economic Model

### 6.1. Ecosystem Construction and Foundation Investment

As mentioned earlier, Halal-Chain will issue tokens called Halal-Chain Coin (HLC) based on Qtum. As the key component of the Halal-Chain ecosystem, the HLC will be defined as the utility tokens to support the companies. The trading token will be used to be circulated across the chain.

Furthermore, as the essential economic instrument, the HLC will be used in many actual cases, such as incentives for product promotions, brand building, etc.

The total number of HLC is 1 billion, which will be distributed as follows:

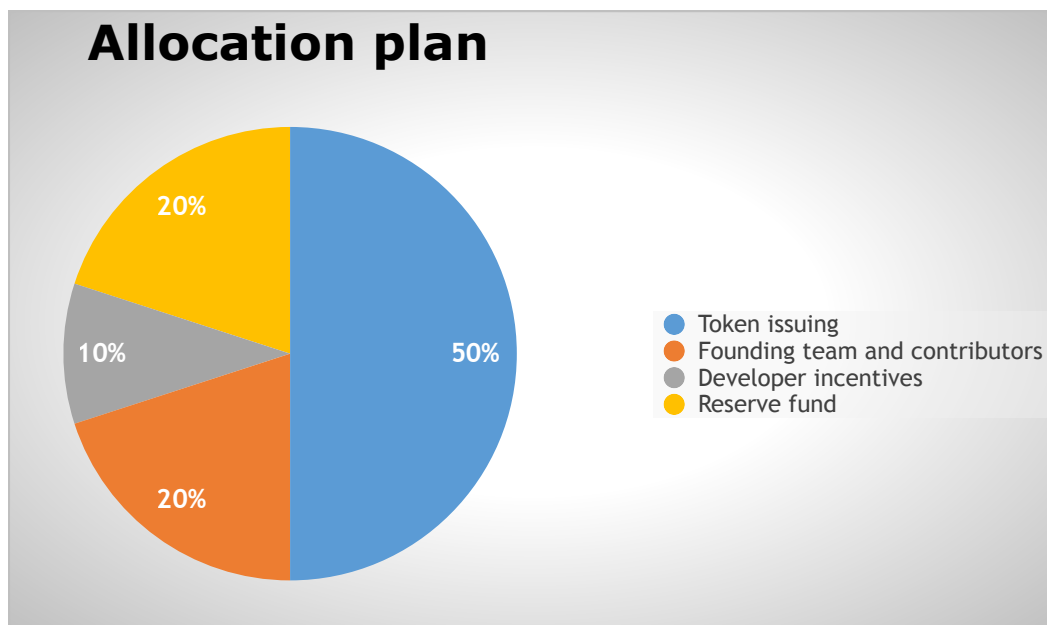

- 500 million (50%) of the total tokens issuance, of which 1.6% is allocated to the angel phase. Approximately 50% of the 500 million is allocated to the private phase, which is only accessible to institutional investors. 16% is allocated to the traditional stakeholders in the industry. 32.4% is allocated to the Initial Coin Offering (ICO) phase. The income will be used to support further development of Halal-Chain, including technology development, market expansion, legal advice etc.
- 200 million (20%) is allocated to the founding team and contributors who provided resources and technical support to the Halal-Chain development during the early stages.

- 200 million (20%) of the tokens are reserved for the Halal-Chain investment foundation, which will use these tokens to invest in the actual enterprises in the consortium chain. This is to facilitate the fast applications of Halal-Chain technologies in the food industry which gives rise to a nourished Halal-chain ecosystem.
- 100 million (10%) is allocated to the developers' incentive. This allocation will be used to reward the developers, individuals or entities that would play a significant role in contributing to the community development.

## 6.2. Ecosystem Construction

A certain share of the funds raised through ICO will be allocated to optimize the platform, accomplish the task of source-code opening and reward developers for code development within the community. The Halal-Chain and Qtum blockchain will jointly conduct blockchain technology development and operate the Halal-chain IoT device. It will facilitate all the stakeholders in the chain to adopt a uniform, fully compatible device enabling the enterprises to transmit the data to Halal-Chain platform smoothly.

## 6.3. Foundation Investment Strategy and Portfolio

As part of Halal-chain ecosystem, the foundation will hold a certain number of tokens to invest in the actual industry stakeholders, intending to facilitate the actual use of Halal-Chain technology in the industry, as well as to correlate the tokens with real economy.



## 7. Token Offering Details

The ICO will issue 500 million tokens called Halal-Chain Coins (HLC), which accounts for 50% of the total circulation. It intends to raise 130,000ETH or other equivalent digital currencies.

### 7.1. The token offering is implemented in phases

- *Private offering Phase:*

Many industry leaders and investors made significant contributions during the early development of the Halal-Chain project. To appreciate their input and maintain a long-term partnership with them, 87,600ETH or equivalent cryptocurrency is expected to be raised in this phase.

- *Crowd-Sale Phase*

In this phase, all investors, except China and USA nationals, will have access to the crowd offering to build a diverse international community and expand the Halal-Chain user-base and ecosystem.

### 7.2. Crowd-Sale platform

The crowd-sale platforms will include Halal-Chain official website and other token offering platforms in Dubai, UK, etc.

### 7.3. Crowd-Sale Price

As shown below, price for crowd offering phase: investors will have a declining discount as the crowd offering progresses.

HLC offering Scheme	Crowd-sale Phase			
	Early-bird	Week 1	Week 2	Week 3
Percentage of Tokens offered	10%			
Number of Tokens offered	100 million			
Amount raised from Crowd offering	42400 ETH			
1 ETH =? HLC	2350	2070	1950	1840

**Hard-cap:** HLC offering has a hard-cap of approximately 130,000 ETH or equivalent digital assets at the market price;

- **Soft-cap:** HLC offering has a soft-cap of approximately 100,000 ETH equivalent digital assets at the market price; if total amount raised fell below 100,000, the offering is considered failed.
- **Timescale for Crowd Offering:** Starting from Dec. 12th and lasting for up to 4 weeks or before all tokens are distributed.
- **Over-Subscription:** In the event of Halal-Chain token offering raising more than 130,000 ETH equivalent digital assets at the market price in the crowd-offering, the token offering participating channels will be closed immediately. Even in the case of shutting down participating channels, there is still a chance of over-subscription, whereby the crowd offering receives more than 130,000 ETH, the exceeding amount of funds will be returned to investors within 15 days after the crowd offering. Please be noted that no interest will be paid in such case.
- **Crowd funding failure:** If the crowd offering does not hit the soft-cap, it will be considered as a failed offering. In such case, the offering will be terminated immediately with the exceeding amount of funds returned to the investors within 15 days after the crowd offering.

#### 7.4. Legal issues involved in purchasing tokens

- Most tokens are directly offered as digital assets by the team. In the Private Placement Phase, investors from China and the United States are qualified to participate, because it is considered as an angel investment for the project, which is free from supervision of the

Securities Act and is bound to the Jurisdictional law of China. Except for the Private Placement Phase, the other phases of the Halal-Chain token offering forbid the participation of China and USA nationals.

- After holistic legal frame work and preparation, the Halal-Chain team is taking a highly cautious approach towards legal risks in token offering. On this basis, the Halal-Chain team may adjust the strategy of token offering to minimize legal risk when deemed necessary during the entire course of the offering.
- US investors, as stated in legal regulations, must be whitelisted (a whitelisted investor is someone whose annual income is above 200,000 USD, or someone whose spouse's annual income is above 300,000 US dollars, or someone with a net asset value of over 1 million USD) in order to be considered as "qualified investors". Without being whitelisted and qualified, an American investor is not able to participate in the token offering.
- Non-American investors or non-US investors do not require the same whitelisting procedure imposed on American investors. Nonetheless, because of the strict supervision of American laws, our legal team requires us to select non-American investors by provisions in accordance with the American laws.

## 7.5. Team Allocation

The 20% HLC that rewards the founding team and partners will be immediately and fully locked after the ICO. These restrictions will be lifted gradually according to the project's progress after tokens are listed in the secondary market.

## 7.6. Listing and trading in the secondary market

If the conditions permit, the Halal-Chain plans to get listed on the exchanges and be traded in the secondary market.

## 7.7. The fund raised from ICO will be used for:

Further supporting the operation of Halal-Chain team to accomplish the following major tasks:

- Supporting sustainable optimization and development of the underlying technologies of the consortium blockchain

- Supporting development of cross-chain protocol in partnership with Qtum blockchain
- Halal-Chain product traceability system development
- Halal-Chain community's development and operation
- Investment in the traditional industry stakeholders to facilitate the application Halal-Chain solutions

## 8. Governance and Risk Control

### 8.1. Governance structure

- **Halal-Chain Foundation**

The Organization structure of Halal-Chain Foundation shall consist of community congress, foundation councils and an executive core team, which would operate and govern the community, as well as safeguard and manage the funds raised for the beneficiaries.

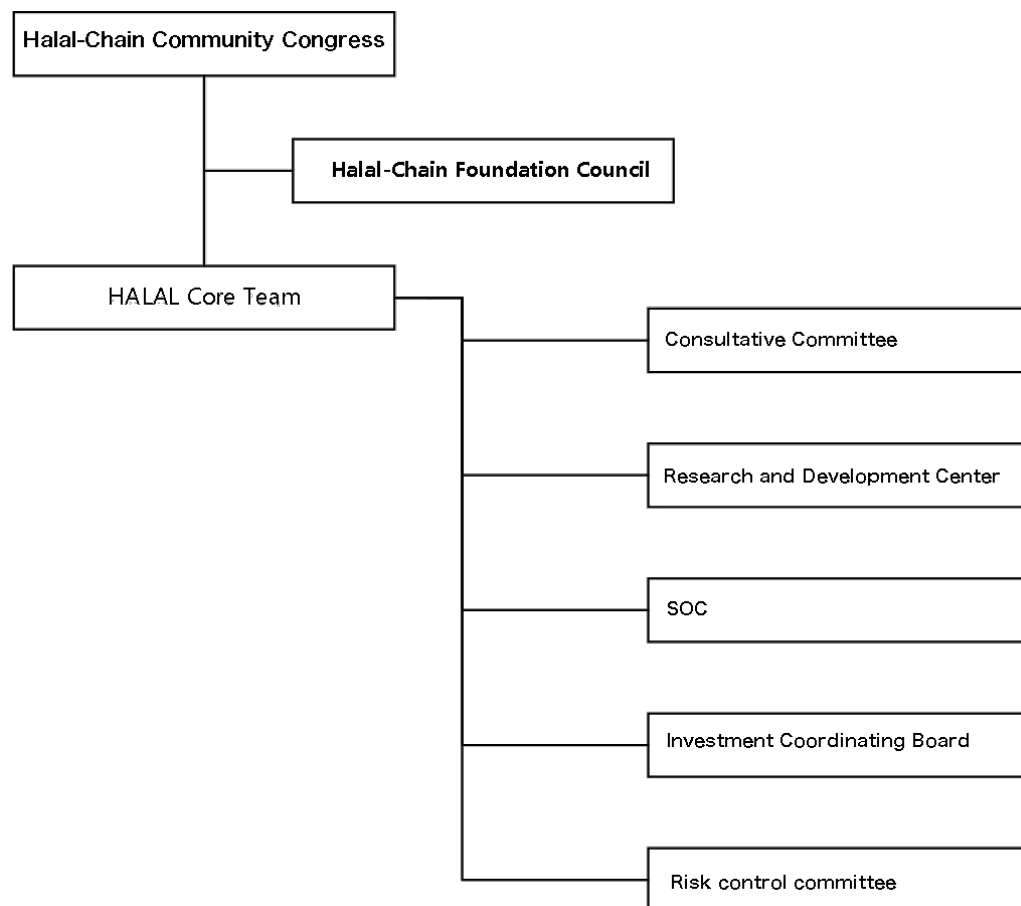

- **Halal-Chain Foundation Council**

The Foundation Council will be responsible for the Halal-Chain Community Congress, which will perform its duty to manage and supervise the executive core members. The council would conduct elections every two years among digital asset holders in accordance with the assets quantities and assets ages respectively.

The First council members would be the Halal-Chain core team due to its key role play in the digital assets issuance. Afterwards, 100 community representatives will be generated according to their weights in the assets quantities and ages respectively. Moving on, 10 foundation council members will be elected and entitled to make decisions on behalf of the foundation. The council will accept investigation during its term and any resolution adopted for implementation should collect voting consent from at least two-thirds of council members.

■ **Halal-Chain Core Team**

The Halal-Chain core team would be responsible for day to day operations consisting of a technical development group, business operation group, financial management & risk control group and quality QC group. Each group would perform its duty to conduct the actual job in a daily manner.

■ **Halal-Chain Community Congress**

The Halal-Chain Community Congress shall be of highest authority, which consists of every digital asset holder in the community with its functions described as shown below:

- To amend Halal-Chain regulation;
- To supervise the implementation of Halal-Chain regulation;
- To elect and change council members;
- To revoke the inappropriate resolutions from council members;
- To approve major and significant changes.

The Halal-Chain regulation is the fundamental guidelines for governance, which would be open for public review from the official website. The Halal-Chain regulation would be officially launched within six months after the trial operation of Halal-Chain, which of the first edition would be developed by the foundation council. The community congress meeting would be organized in very two years. However, any unscheduled congress meeting would take place subject to the will of foundation council members or request from at least one-fifth of the digital asset holders.

## 8.2. Post-ICO – Roles of Global Islamic Economy Investment Foundation

The Global Islamic Economy Investment Foundation will be set-up after the ICO as shown below:

- The foundation will be governed with Islamic Spirit to support and nourish Global Islamic Economy;
- The foundation will have deep engagement with global Halal industry by conducting investments into the ownership of key industry stakeholders and start-ups from upstream, middle stream till downstream;
- The foundation will provide Interest-free loan to the community member enterprises;
- The foundation will act as the fund of fund to enlarge and extend its influence, such as the adoption of Modaraba instrument, which is going to expand the capital pool for 5 to 10 times.
- The underlying assets and holdings of the foundation will be finally exited through listing to global stock market or used as the subject to issue Global Sukuk on Halal industry.
- If the Sukuk adopts Wakala structure, the proceedings of the Sukuk will be 3 times than its relevant underlying asset.

## 8.3. Risk Control

### ■ **Transaction security**

Through the application of Consensus protocol, tamper-proofing, digital signatures, encrypted wallets and other safety measures, Halal-Chain assures the safety of end user account and funds, and provides the highest level of asset safeguarding technology in the financial industry. The data storage, network and other resources will be effectively consolidated, which enables data, application and trading to be integrated into Blockchain Cloud, constructing a safe network environment. In addition, a host of technical and management measures would be adopted to ensure a trustworthy and safe Halal-Chain operation.

### ■ **Auditing**

Halal-Chain Council aims for high standards of good faith, business ethics, obedience and compliance to laws and regulations in its

jurisdiction. Offering transparent financial management; Halal-Chain Council will invite a world-renowned Auditor to review and evaluate Halal-Chain foundation's financial information. Halal-Chain will release the result of these reports without any reservation or intervention.



## Members

- **Core Members**

<p><b>Sultan Al Howymel</b> Co-Founder Dubai UAE</p>	<p>Sultan Al Howymel is an entrepreneur, researcher and a professional financial consultant who have well managed several researches and projects in the field of banking, finance, technology, telecom and media. Al Howymel achieved an official financial consultant license in 2011. Through technological innovation, keen business strategy and aggressive business tactics, Al Howymel founded two organizations, a financial consultation organization known as Financial Experts Center, founded in 2012. Later in 2015, Al Howymel collaborated with Dubai Airport Freezone Authority to form an initiative to articulate the vision of His Excellency Sheikh Mohammed bin Rashid Al Maktoum to position Dubai as the Capital of Islamic Economy, founding International Center of Islamic Economy.</p>
<p><b>Prof. Dr. Abdul Salam</b> Co-Founder Nigeria</p>	<p>Prof. Dr. Abdul Salam is an expert in Islamic Economics and finance. He has great experience in both practical and Academic research in Islamic economics and finance. He holds a doctorate degree from International Islamic University Malaysia (IIUM) (2005 in Shar'iah law. He is currently Senior Advisor at International Centre of Islamic Economy and Associate Professor in the University of Modern Sciences, College of Business. and Manager, Noor Investment Group Dubai UAE</p>
<p><b>Mr. Abdullah Han Guangyu</b> Co-founder China</p>	<p>Founder of Al-Sadiq Consulting Co Ltd, the first Islamic Finance investment consultancy in China. Mr. Abdullah is the founder of S.I.B.F.P, a think tank based in Hong Kong for Islamic Economic Studies. In tandem, he is also the Director of EHALFRESH.COM, an e-commerce platform for Halal food.</p> <p>Among his other achievements; is riding to be the Director of Mingdao culture (a creative industry player), Xun Lian Technologies (a 3-D printing company) and being an advisor to the China-Arab states Financial cooperation, CPEC, and HongKong Islamic Finance forum</p>

<p><b>Saad Mohib</b></p> <p>Co-Founder</p> <p>Australia</p>	<p>His career started with UK Management Consulting firm, in Australia in 2007. Later moved to Singapore headed Australia, Malaysia and Singapore. In 2010 Saad founded Business Technology Innovations, a digital platform company building unique custom digital platforms for businesses in ASEAN.</p> <p>His latest venture is Foin.re. Major in blockchain technology development, artificial intelligence and Internet of Things. Successfully completed Bitcoin exchange in Hong Kong and blockchain social entrepreneurship projects in UK &amp; Switzerland.</p> <p>Currently also serving on the Executive Board of Malaysia Infocomm Foundation and the Advisory board of StartsupKL.</p> <p>MBA from Nottingham Trent University, Management program from University of London and Fellow of Harvard Leadership Excellence.</p>
<p><b>Dr Farrukh Habib</b></p> <p>Co-Founder</p> <p>Pakistan</p>	<p>Dr. Farrukh Habib is a Sharia (Islamic jurisprudence) and Islamic finance expert. He is Researcher at International Shari'ah Research Academy for Islamic Finance (ISRA); Sharia Advisory Board Member of Salihin Shariah Advisory Sdn Bhd; Co-editor of ISRA International Journal of Islamic Finance (IIJIF); and Reviewer of various well-reputed academic journals. He has been involved in numerous researches, corporate training, workshops and consultation projects on Islamic finance. He has been a prolific contributor to numerous academic journals, reports, research papers and business magazines, and presented at several international conferences and seminars. He has also been invited to many Islamic finance events as a guest speaker. His current interests are capital markets, sukuk, fintech, blockchain, virtual currencies/Bitcoin, crowdfunding, ethical and social finance.</p>
<p><b>Dr. Sulaiman Liu Jiujiang</b></p> <p>Co-founder</p> <p>Malaysia</p>	<p>Dr. Sulaiman is the Co-founder of Alsadiq Consulting Sdn. Bhd., the first Islamic Economy and Finance consultancy firm in Malaysia dedicated to the Belt &amp; Road Initiative.</p> <p>He also holds the positions of co-Founder with SIBFP, a think tank based in HK for Islamic Economy study; Director of Finance &amp; Investment with YMM(MAL) Sdn. Bhd., an Eco Waste Management and project consultancy company; Advisory Board Member to Pixel Play Sdn. Bhd., a leading ASEAN creative industry player.</p> <p>In the past, he had been the invited Speaker of various International Events like CPEC &amp; Islamic Finance International Forum and OIC Biz Economy &amp; Trade Forum etc.</p>

<p><b>Ren Zhiqiang</b> Blockchain core-developers</p>	<p>Information and communication engineering, the original Huawei distributed storage design architect, Mr.Ren has led the completion of Huawei's first generation of distributed storage FusionStorage development. He was the head of the research team of Block Chain in Huawei. He was responsible for the design of system architecture and the development of core code of block chain. The research direction was focused on the development of the tower. Master graduated from Xi'an Jiaotong University</p>
<p><b>Fan Xiaobo</b> Blockchain core-developers</p>	<p>The original Huawei fixed-line product line senior engineer, Mr.Fan has been participate in the realization of a number of major R &amp; D projects, has been for 2 years won the annual president award; participate in the design of Huawei's first generation of block chain system architecture design and development, Focus on the direction of the development of intelligent contract for the ether square. Master graduated from the Department of Computer Science, Wuhan University.</p>

- **International Advisory Board**

<p><b>H.E Sultan bin Saeed Al Mansoori</b></p>	<p>His Excellency Sultan Bin Saeed Al Mansoori has been appointed as Minister of Economy in the UAE, effective 17th of February, 2008. His Excellency Sultan holds a Bachelor's degree (B. Sc.) in Industrial Engineering &amp; Management Systems from Arizona State University - USA. He also has a Diploma in Computer System Analysis from the Institute of Computer Technology, Los Angeles, California - USA.</p> <p>In addition to his position as Minister of Economy, His Excellency Sultan holds the positions below :</p> <ul style="list-style-type: none"> <li>• Chairman of the Supreme Committee for Consumer Protection</li> <li>• Chairman of the Coordinating and Economic Cooperation Committee</li> <li>• Chairman of the National Committee for the Follow-up Program of Investment Climate</li> <li>• Chairman of the Board of Directors of the Securities and Commodities Authority</li> <li>• Chairman of the insurance Authority</li> <li>• Chairman of the Federal Civil Aviation Authority</li> <li>• Member of the Ministerial Committee for Legislation</li> <li>• Member of the National Committee on Population Composition</li> <li>• Member of the Committee of Finance and Economy</li> </ul>
<p><b>H.E Abdulla Sultan Alfan Alshamsi</b></p>	<p>H.E Abdulla Sultan Alfan Alshamsi is the Assistant Undersecretary, Industrial Affairs, Ministry of Economy, UAE. He held Memberships of boards of directors as below among others:</p> <ul style="list-style-type: none"> <li>• Member of the Board of Directors of Wall Street Exchange - Chairman of the Executive Committee</li> <li>• Vice Chairman of the Emirates Marketing &amp; Promotion Corp.</li> <li>• Board Member of the Emirates Courier Services – Empost</li> <li>• Board Member of the Emirates Marketing &amp; Promotion Corp.</li> <li>• Board member of the Gulf Organization for Industrial Consulting (GOIC)- Qatar</li> <li>• Vice President of the Technical Committee of the Board of Directors of the Gulf Organization for Industrial Consulting – Qatar</li> <li>• member of the Executive Council of the Organization of Arab Industrial Development and Mining - Kingdom of Morocco</li> </ul>
<p><b>H.E Ahmad Bin Ghannam</b></p>	<p>Adviser to the Undersecretary &amp; Ag. Executive Director in Abu Dhabi Department of Economic Development, His Excellency also holds the positions below among others:</p> <ul style="list-style-type: none"> <li>• launched Abu Dhabi Investment office</li> <li>• leading the economic planning and statistics sector in Abu Dhabi Department of Economic Development (AD-DED)</li> </ul>

<p><b>Yen Wan Zaheran</b></p>	<p>Yen @ Wan Zaheran bt Mohd Noor, is currently the share-holding partner and International Advisory Board member of Al-Sadiq Consulting Sdn. Bhd. She is also a non-executive Director of YMM (Mal) Sdn Bhd, a Project Management Consultancy company and the Vice-President of International Relations of Dubai Barakah Capital Holdings. With 23 years of experience in diversified market with Government Link Agencies and Private Corporations, she was the SUSK (Setiausaha Sulit Kanan to Minister) of MOSTI. Her last postings were in Teheran and Marshad, Republic People of Iran among others.</p>
<p><b>Tang Ling</b></p>	<p>Founder &amp; CEO of Ziggurat Tech Founder of Inkchain;</p> <p>An early adoptor in blockchain in China. He is an expert of intellectual property and dedicates to the practical application of blockchain in creative industry. He worked on numerous online blockbusters with Tencent named Tronisister, and participated in the incubation of many intellectual properties from renowned writers, such as Ping'ao JIA, Lai' A, Tong SU, etc. He is also the initiator of Blockchain Technology and Law Innovation Research Lab of Xi'an Jiaotong University, a member of consultative committee of APEC Future College, a Global Shaper with the World Economic Forum, and senior member of Silk Road Innovative Design Alliance</p>
<p><b>Chen Chang</b></p>	<p>CTO of Ziggurat Tech; Chief Scientist of Inkchain.</p> <p>A Masters' degree holder from Tsinghua University. He was a senior researcher at IBM and has been the one of the earliest researchers and promoters of blockchain technology. Chen is an expert in cloud computing, blockchain, machine learning, etc. He is the core developer of Hyperledger open source project, and has rich experience in the underlying development and application practice of blockchain. He was in charge of architecture design and implementation of the enterprise blockchain solution and has led and developed several blockchain service platforms.</p> <p>He also co-edited "The Principle, Design and Application of Blockchain".</p>

<p><b>William Van Lith</b></p>	<p>An experienced entrepreneurial professional bridging the gap between business and IT. Deep knowledge and contacts in the Dutch technology sector. Expertise in building data science &amp; engineering teams and known with the overall trends in the Big Data and AI landscape.</p> <p>Founding Partner at Xomnia, fastest growing Dutch Big Data analytics company with access to the best talent in Europe, as well an ecosystem of innovation and invaluable experience and new joint ventures, which has been accumulated over the years. Xomnia won the prestige FD Gazelle in 2017, an award for one of the fastest growing companies in the Dutch region.</p>
<p><b>Umar Munshi</b></p>	<p>Founder and CEO of EthisCrowd.com, a Real Estate Islamic Crowdfunding Investment platform and also Chairman of Islamic Fintech Alliance</p>
<p><b>Ronnie Faizal Tan</b></p>	<p>Founder of My Outlets.</p> <p>The objective of My Outlets is to create a retail platform for the Halal Food Manufacturer to sell their products to the consumers directly. In 2015, he registered Haladeen.com to consolidate the Global Halal Product and Services in the e Commerce market place. In 2017, MyOutlets has expanded our networks from Singapore to Japan, South Korea, Malaysia and China.</p>

- Investor

<b>Ryman</b>	Hcash Honorary president, Famous blockchain investors, Australia's silver capital founder,
<b>Patrick Shuai</b>	Patrick is the founder of Qtum.
<b>H.E Sultan bin Saeed Al Mansoori</b>	<p>His Excellency Sultan Bin Saeed Al Mansoori is the current Minister of Economy in the UAE, since 17th of February, 2008. His Excellency also holds the positions below among others:</p> <ul style="list-style-type: none"> <li>Chairman of the Coordinating and Economic Cooperation Committee</li> <li>Chairman of the National Committee for the Follow-up Program of Investment Climate</li> <li>Chairman of the Board of Directors of the Securities and Commodities Authority</li> <li>Chairman of the insurance Authority</li> <li>Member of the Committee of Finance and Economy</li> </ul>
<b>H.E Abdulla Sultan Alfan Alshamsi</b>	<p>H.E Abdulla Sultan Alfan Alshamsi is the Assistant Undersecretary, Industrial Affairs, Ministry of Economy, UAE. He held Memberships of boards of directors as below among others:</p> <ul style="list-style-type: none"> <li>Member of the Board of Directors of Wall Street Exchange - Chairman of the Executive Committee</li> <li>Vice Chairman of the Emirates Marketing &amp; Promotion Corp.</li> <li>Board Member of the Emirates Courier Services – Empost</li> <li>Board Member of the Emirates Marketing &amp; Promotion Corp.</li> <li>Board member of the Gulf Organization for Industrial Consulting (GOIC)- Qatar</li> <li>Vice President of the Technical Committee of the Board of Directors of the Gulf Organization for Industrial Consulting – Qatar</li> <li>member of the Executive Council of the Organization of Arab Industrial Development and Mining - Kingdom of Morocco</li> </ul>
<b>H.E Ahmad Bin Ghannam</b>	<p>Adviser to the Undersecretary &amp; Ag. Executive Director in Abu Dhabi Department of Economic Development, His Excellency also holds the positions below among others:</p> <ul style="list-style-type: none"> <li>launched Abu Dhabi Investment office</li> <li>leading the economic planning and statistics sector in Abu Dhabi Department of Economic Development (AD-DED)</li> </ul>

<b>William Van Lith</b>	<p>An experienced entrepreneurial professional bridging the gap between business and IT. Deep knowledge and contacts in the Dutch technology sector. Expertise in building data science &amp; engineering teams and known with the overall trends in the Big Data and AI landscape.</p> <p>Founding Partner at Xomnia, fastest growing Dutch Big Data analytics company with access to the best talent in Europe, as well an ecosystem of innovation and invaluable experience and new joint ventures, which has been accumulated over the years. Xomnia won the prestige FD Gazelle in 2017, an award for one of the fastest growing companies in the Dutch region.</p>
-------------------------	--



## Partners

### ◇ International Center of Islamic Economy (Dubai)



The creation of International Center of Islamic Economics was formed through the initiative of Dubai Capital of Islamic Economics and driven by the growing need in the market for innovation, development and active practical applications. The Center focuses on providing Islamic Economy services through studies and databases, periodic events, annual reports, and scientific analyses to address current and future market issues. The Center aims to stimulate innovation and creativity by enriching the knowledge in Islamic Economy.

### ◇ Al-Sadiq Consulting Ltd



Al-Sadiq Consulting is an ethical investment advisory firm based in China, focused on creating enduring value for its shareholders, customers, employees and communities. As the first firm in China founded to advocate Islamic Economy and Finance in Greater China region and provide Shariah compliant consultancy services, Al-Sadiq Consulting is considered a milestone of Islamic Finance development in China.

### ◇ EHALFRESH.COM



Beijing Newtery Hala fresh Net.Co.,Ltd. is an Innovative Internet Company that specializing in online trading of Halal Food, Company Project "Ehalfresh.com --International trading platform of Halal Food" integrates the original Halal Food with high quality . Resources are all over the world, and in accordance with the business philosophy "Quality and Original", works out the

global Halal Food and Halal Food Industry's channel circulation problems faultlessly, provides original, healthy, ecological, environmental high-quality Halal Food to the global Muslims and the general intention buyers.